

N13.660 CR2

SPECIFICATIONS



Power at crankshaft	485 kW [659 hp]	Engine base	John Deere
Displacement	13.6 l [830 in³]	Fuel system	Electronically controlled unit injectors
Configuration	6 cylinders in line	Air intake	Turbocharged Air-to-seawater aftercooler
Operation type	4 strokes Diesel	Cooling	Closed cooling with heat exchanger
Bore & Stroke	132 x 165 mm [5.2 x 6.5 in]	Max mounting angle	0° Front down 12° Front up
Compression ratio	16 : 1	Alternator	24 Volt 100 Amp
Rated speed	2100 rpm	Rating	M4
Idling speed	600 rpm	Emission compliance	IMO Marpol Annex VI NRMM (97/68/EC) Tier 3 EPA marine Tier 3 RCD2 2013/53/EU
Peak torque	2877 Nm	Dry weight	1380 kg [3042 lbs]
Peak torque speed	1600 rpm		

N13.660 CR2

485 kW [659 hp] at 2100 rpm

TECHNICAL DESCRIPTION

ENGINE BLOCK

- Replaceable wet-type cylinder liners
- 4 Valves per cylinder
- Directed top-liner cooling
- Watercooled exhaust manifold

FUEL SYSTEM

- Electronically controlled unit injectors
- Primary & secondary fuel filter

LUBRICATION SYSTEM

- Replaceable full-flow oil filter
- Oil dipstick
- Oil cooler

COOLING SYSTEM

- Closed cooling with heat exchanger
- Gear driven self-priming raw water pump
- Coolant circulating pump
- Water cooled exhaust elbow

ELECTRICAL SYSTEM & INSTRUMENTATION

- 24V / 100A alternator
- 24V starter motor
- Complete instrumentation including key switch and alarms
- Extension cable harness with plug-and-play

AIR INTAKE

- Water cooled turbocharger
- Air-to-seawater aftercooler

OTHER FEATURES

- Flywheel SAE 1
- Flexible engine mounting
- Damper pulley

OPTIONAL SYSTEMS & ACCESSORIES

- Keel cooling adaptation
- Dry exhaust elbow
- Complete marine propulsion systems
- Marine transmission adaptation kits
- Throttle and shift controls
- Additional instrumentation, Flying bridge extension harness
- Rigid engine mounting
- Power take off
- Type approval

RATINGS

- Up to 3000 annual operating hours
- Load factor up to 40%
- Full power for no more than 1 hour out of each 12 hours of operation. The remaining operation time must be at or below cruising speed

TRANSMISSIONS

- Contact your Nanni representative for more details and availability about transmissions types and models range.

PERFORMANCE CURVES

POWER AT CRANKSHAFT

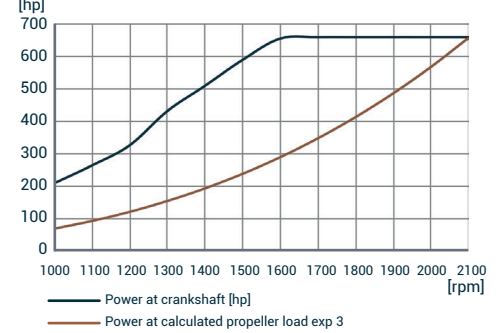

TORQUE AT CRANKSHAFT

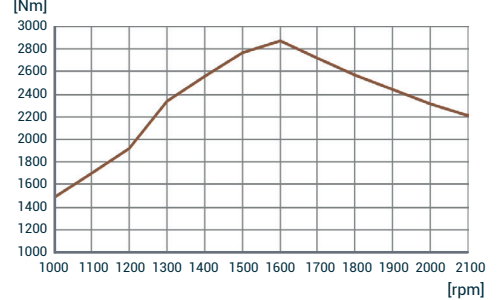

FUEL CONSUMPTION

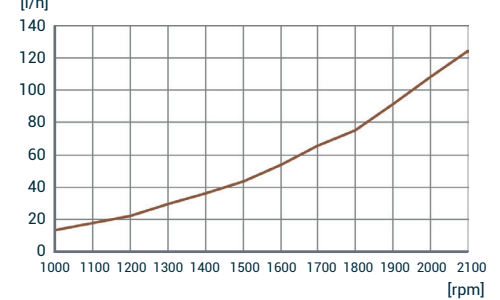

DIMENSIONS

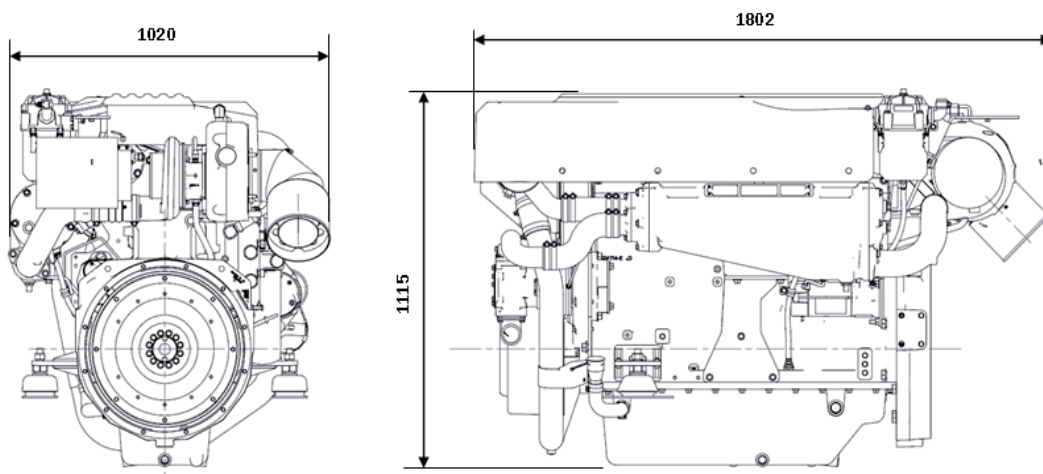

NANNI INDUSTRIES S.A.S.

11, Avenue Mariotte - Zone Industrielle
33260 La Teste - France
Tel: +33 (0)5 56 22 30 60
Fax: +33 (0)5 56 22 30 79

Technical data according to ISO 8665. This document is not contractual. Nanni reserves the right to modify any of the characteristics stated in this document without notice, in a constant effort to improve the quality of its products. Images and illustrations may show non standard equipments. All combination of equipment & accessory are not available.

DGBXXC01046